

MARVEL-SCHEBLER PRODUCTS DIVISION

BORG-WARNER CORPORATION

7/11/62

MAIN OFFICE AND FACTORY
DECATUR, ILLINOIS, U. S. A.

AIRCRAFT

July 2, 1962

SERVICE BULLETIN

#A11-62

TO: All Outlets

SUBJECT: Field Modification of A10-3878 Aircraft Carburetor into A10-3878-M
As Applied to Mooney Aircraft Only.

Improved performance can be realized by field modifying the A10-3878 carburetors used on the Lycoming O-360-A1A and O-360-A1D Engines used in Mooney Aircraft Models M20B and M20C, Serial Nos. 1701-2296.

This conversion can be accomplished by any A & P with standard shop tools and kit #A666-660.

A666-660 Kit Contains One Each

Sym.	Part No.	Part Name
1	A16-A31	Bowl Gasket
2	A16-A30	Nozzle Gasket
3	A16-A56	Economizer Gasket
4	A16-A42	Power Jet Gasket
5	A47-755	Nozzle Assembly
6	#9 Drill	(.196)
7	A60-A127	Nozzle Vent Bushing
8	A229-589	Idle Tube
9	A66-20	Economizer Safety Wire
10	A298-1	Economizer Lead Seal

INSTRUCTION SHEET A11-62

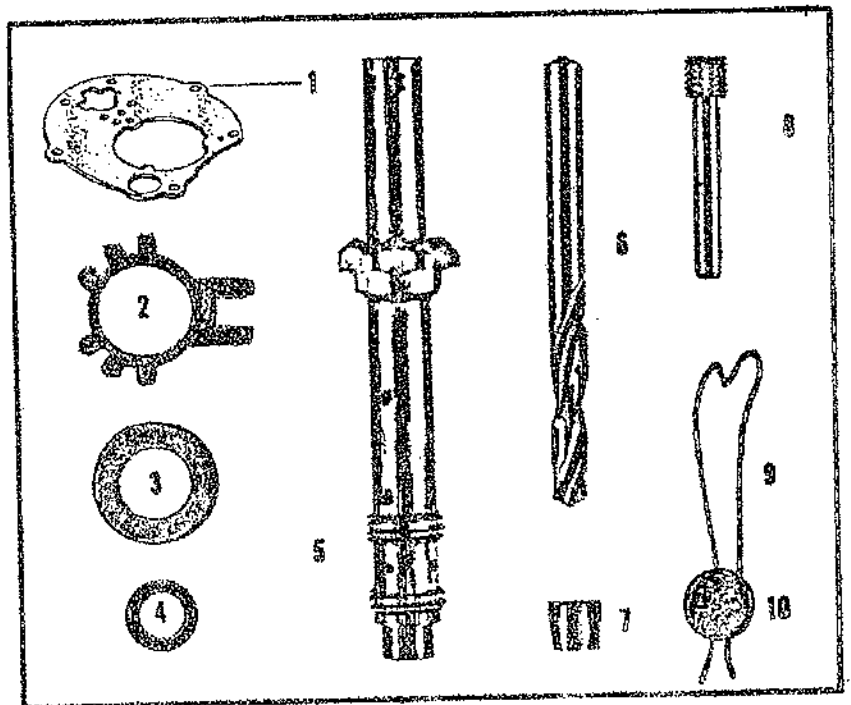

Due to changes in the casting, in some instances it will be necessary to counter-bore nozzle vent channel as shown for the A60-A127 restriction bushing. A #9 drill (.196) is supplied in the kit for this purpose.

(OVER)

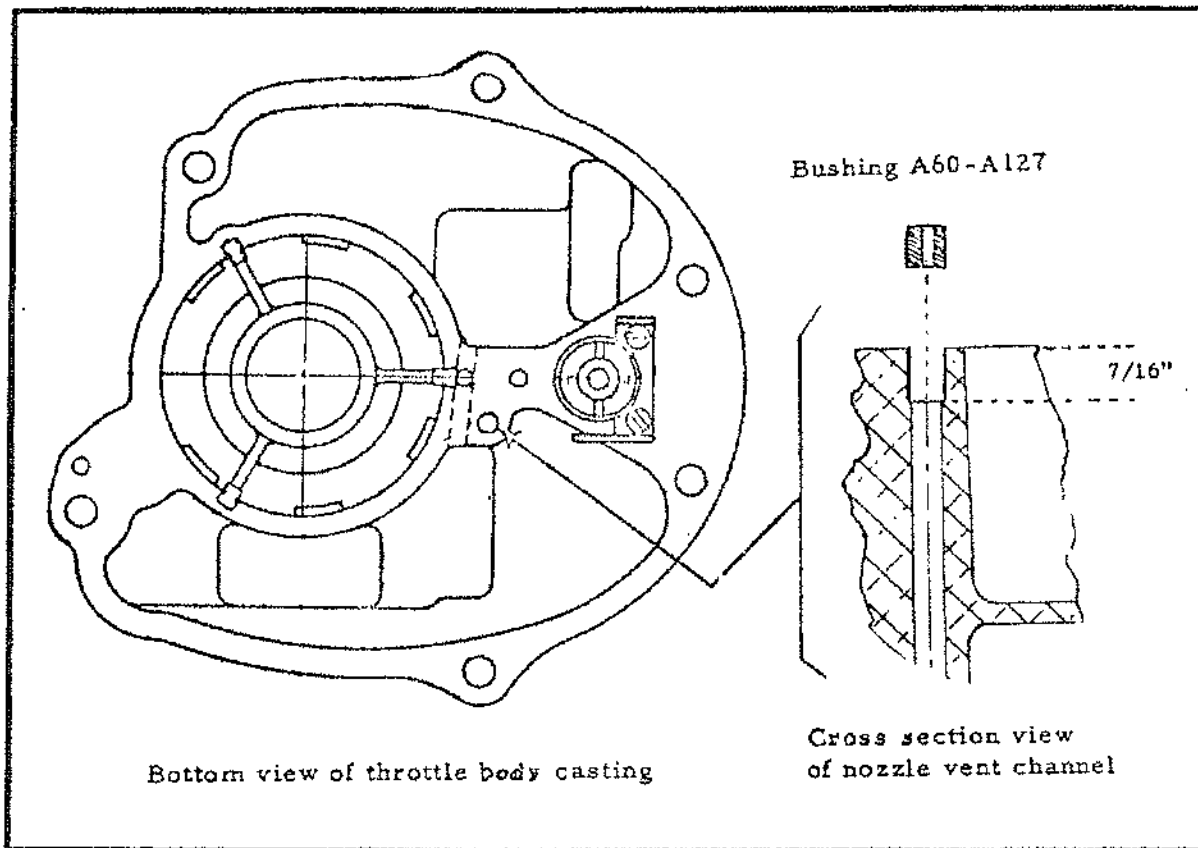

Very carefully counterbore this channel to a depth of 7/16" using the #9 drill. Clean out all chips after drilling (clean this channel by removing the economizer plug and blow out with compressed air with the throttle valve in a closed position).

Very carefully press in place bushing #A60-A127 flush with the casting face, avoid any burrs which could change this restriction.

While the carbureter is down for modification be sure to comply with the long-lok safety features required in AD-62-4-2.

Reassemble the carbureter using the new nozzle A47-755, Idle tube A229-589 and use the new gaskets supplied in kit.

Reset the economizer using M-94 gage plus 1½ turns.

Stamp a small "M" Thus: A10-3878-M on the name plate to identify the conversion.

Kit #A666-660 is available from your Marvel-Schebler Distributor at \$12.80 each list.

MARVEL-SCHEBLER PRODUCTS DIVISION

R. T. Massey
R. T. Massey
Service Sales Manager